

BMP068-S CRANE LIFT MAN CAGE

www.bremco.com.au



The Bremco BMP 068-S Crane Lift Man Cage allows up to 2 people to be lifted using an overhead crane system.

The design strictly adheres to Australian Standard AS1418.17. It has a four point lift (standard) as well as harness attachment points and has a 500kg working load limit. 4-Leg Chains are included

All units are individually proof load tested, tagged and compliance plate and serial number attached. All Bremco crane lift attachments are also proof load tested in accordance with AS4991.

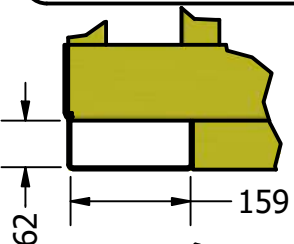
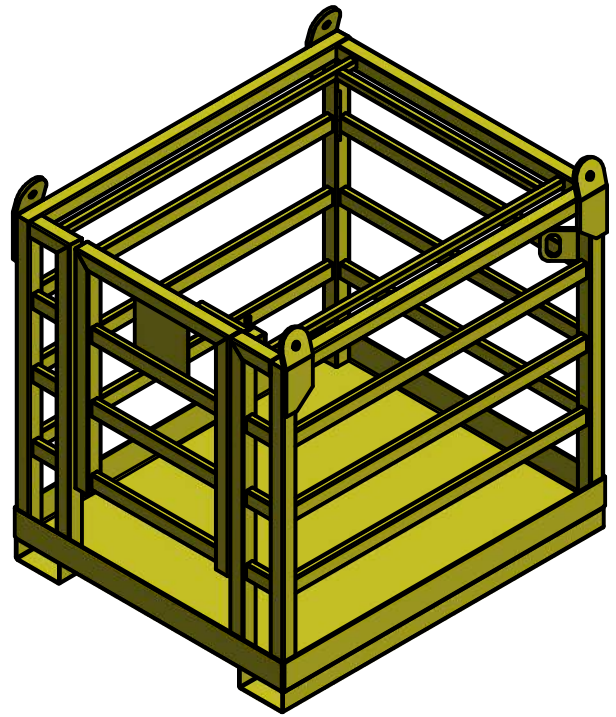

DETAIL A
SCALE 1 / 10

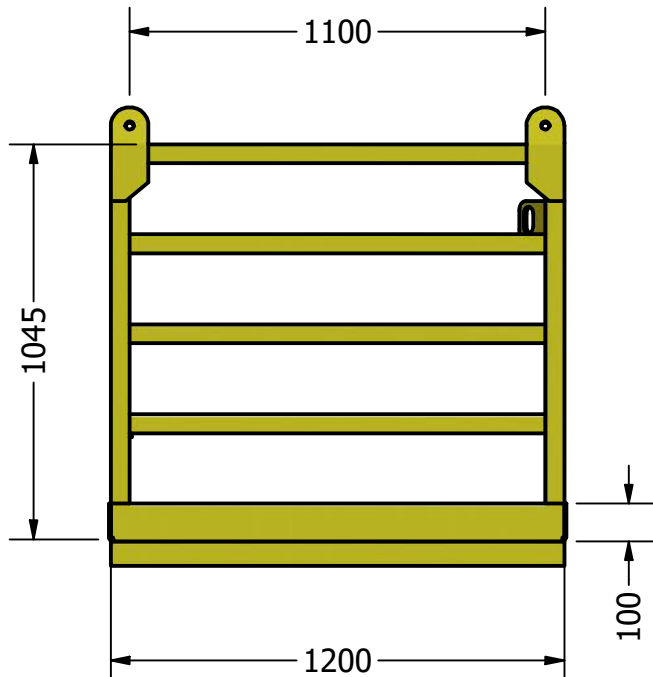
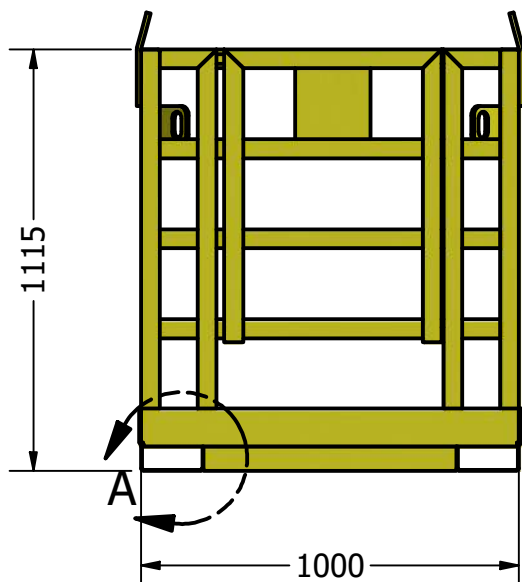

FINISH: P/C SAFETY YELLOW	
WLL: 500kg	
HCoG: N/A	VCoG: N/A
TARE: 180kg	
STANDARDS: AS1418	

NOTES:
SPECIFICATIONS SUBJECT TO CHANGE WITHOUT NOTICE
 This document is the property of Bremco Metal Products P/L. It must not be copied or reproduced without the written consent of the company.

BREMCO METAL PRODUCTS	
BMP068-S	
DRAWING #: 068-S	DATE #: 29/03/2021
SHEET #: 1 of 1	REVISION: A