

BMP003 - CLASS 2 FORKLIFT EXTENSION SLIPPERS

www.bremco.com.au



Product Description

Made in our Australian Factory
Bremco's Forklift Extension Slippers allow you to temporarily lengthen the tynes of your Fork Truck for load stability and are ideal for large crates or machinery items.

The tapered slim profile of our Forklift Extension Slippers are made from fully fabricated plate sections.

IMPORTANT NOTE

In accordance with AS2359.15 Forklift Slippers for general use should be no longer than 167% of the supporting forklift tyne length. If the slippers are longer than this, then their use shall be restricted to their specified application.

Finish: Hot Dip Galvanised

NB: Complies with AS2359.15

Compliance plate and serial number attached

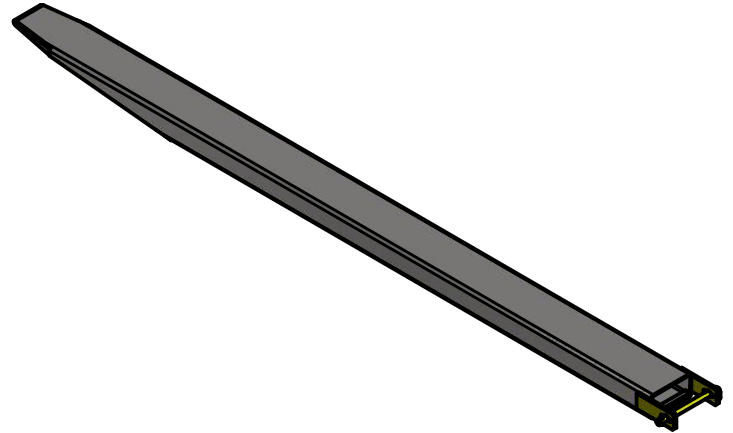

DETAIL B
SCALE 1:4

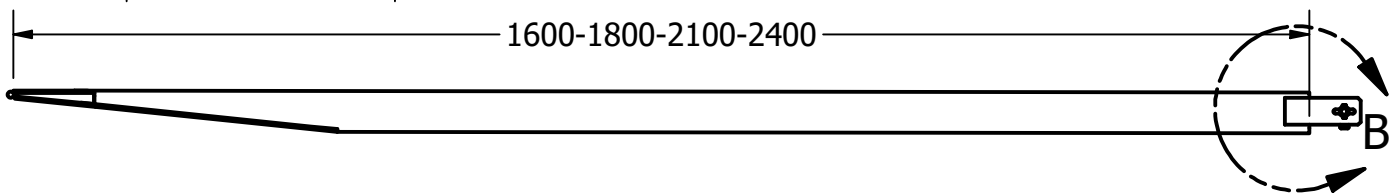
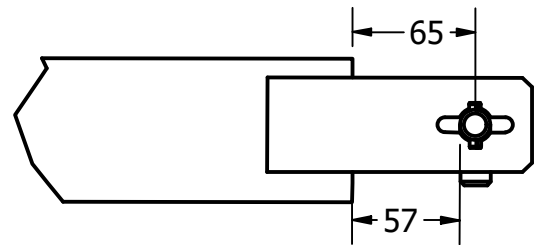
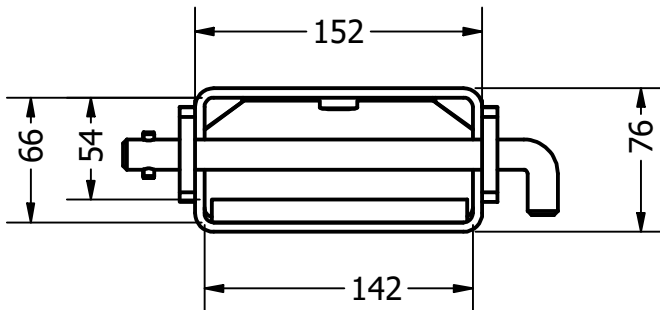

SPECS				
LENGTH	HCoG	VCoG	WEIGHT	WLL
1600	644	42	46	3000KG
1800	740	42.5	53	3000KG
2100	888	43	63	3000KG
2400	1053	43.5	73	3000KG

FINISH: HDG

WLL: 3000

HCoG: N/A

VCoG: N/A

TARE: N/A

STANDARDS: AS 2359

NOTES:

SPECIFICATIONS SUBJECT TO CHANGE WITHOUT NOTICE

This document is the property of Bremco Metal Products P/L.

It must not be copied or reproduced without the written consent of the company.

BREMCO METAL PRODUCTS

BMP003-CL2-16-18-21-24

DRAWING #:

003-CL2-SPEC

SHEET #:

1 of 1

DATE #:

2/08/2019

REVISION:

A