

Bremco manufactures the BMP028 Step Pick Trolley for easy manoeuvrability in any warehouse or factory location where the shelving is above standard height.

Safety is assured with support handles and the three steps are spring loaded using our unique gas strut system. This means that when weight is placed on the steps, positive traction is applied and the trolley will not move.

SPECIFICATIONS

- Size: 1500mmL x 600mmW x 1600mmH
- WLL: 400kg
- Weight: 49kg
- Finish: powder coated blue
- Wheels: 125mm diameter blue rubber castors
- Top Step Height: 660mm

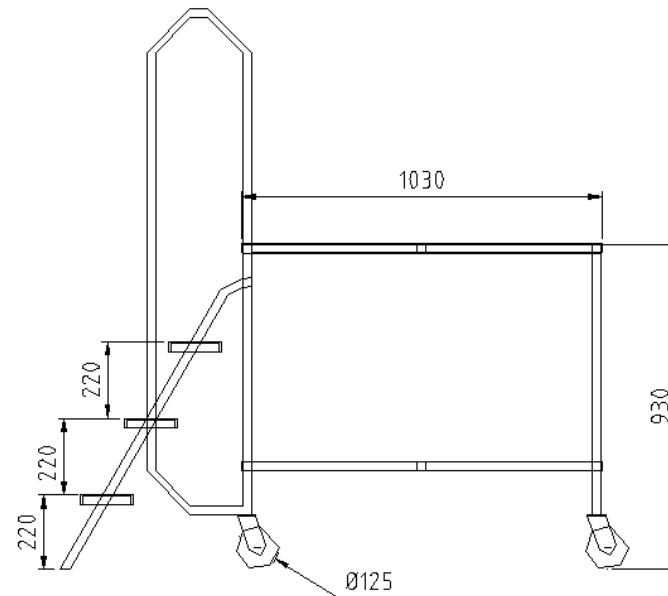
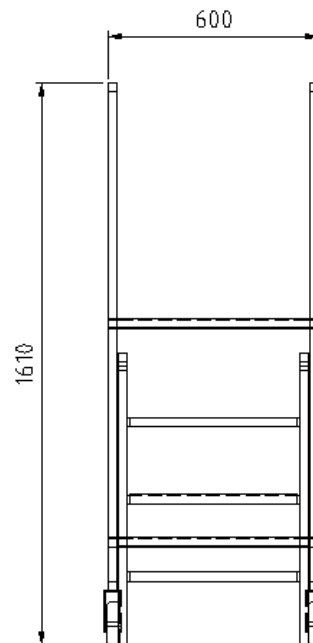

SPECIFICATIONS SUBJECT TO CHANGE WITHOUT NOTICE

In some cases, please allow up to 6 weeks manufacturing time.



Bremco Metal Products Pty Ltd

37 - 43 MacBarry Place Rocklea 4106
Ph: 1300 273 626 Fax: 07 3216 7909

Product
BMP028
Step Pick Trolley
3 Steps
Drawing
BMP028-SALES

| | | |
|---------------------------------|-------------------------|----------------------|
| Drawn by CF | Checked by BM | File SPECS |
| Drawing Number 028/10 | Revision A | Scale NTS |
| | | Date 04/12 |