

BMP069-B - FORKLIFT BAG LIFTER

www.bremco.com.au



Product Description

Use your fork lift truck for the safe transportation and distribution of bulk bags with the Bremco Forklift Bulk Bag Lifter (Raised).

This bulk bag lifter allows easy unloading of shipping containers with bulk bags stacked two high.

Specifications

- Size: 2275mm x 872mm x 800mmH
- WLL = 1500kg
- Weight = 151kg
- HLC: 1720mm
- Tyne Pockets: 190mm x 74mm
- Tyne Pocket Centres: 600mm
- Finish: Painted Enamel
- NB: Compliance plate attached

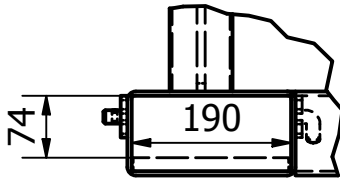
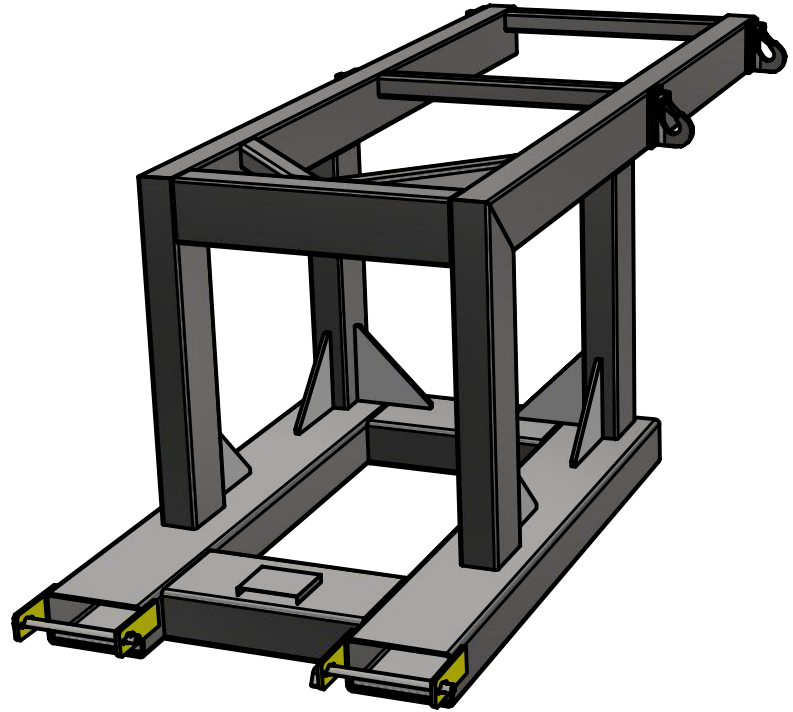

A (1 : 9)

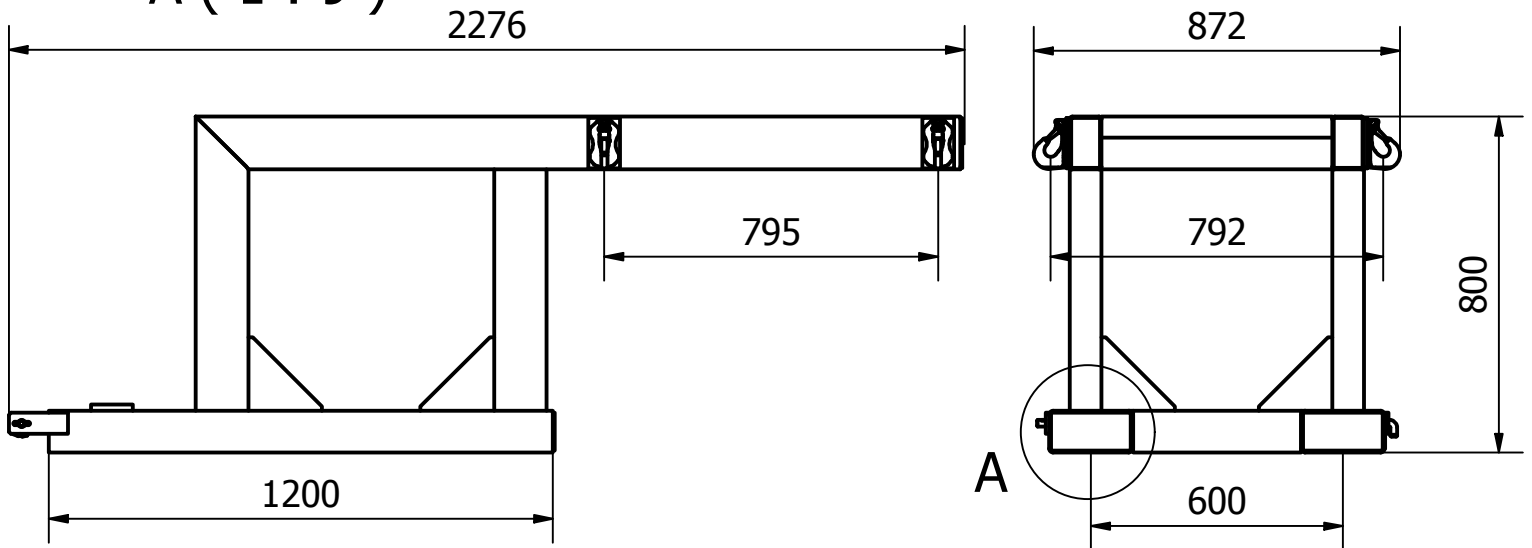

FINISH: PAINTED ENAMEL

WLL: 1500Kg

HCoG: 854

VCoG: 345

TARE: 151.147 kg

STANDARDS:

NOTES:

SPECIFICATIONS SUBJECT TO CHANGE WITHOUT NOTICE

This document is the property of Bremco Metal Products P/L. It must not be copied or reproduced without the written consent of the company.

BREMCO METAL PRODUCTS

BMP069-B

DRAWING #: 069-B

SHEET #: 1 of 1

DATE: 9/08/2017

REVISION: B