

BMP069-C2T - CRANE LIFT BULK BAG LIFTER

www.bremco.com.au



Bremco's BMP069-C2T Crane lift Bulk Bag Lifters allow operators to transport and dispense Bulk Bags in a safe manner using an overhead crane or Jib.

The Bulk-Bags can be located on the four hooks allowing lateral movement of the bag and easy dispensing with the tied base cleanly exposed.

This Crane lift Bag-Lifter is a fully certified lifting device and comes standard with a compliance plate attached.

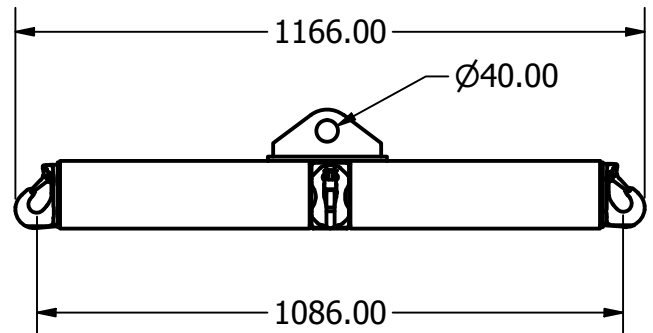
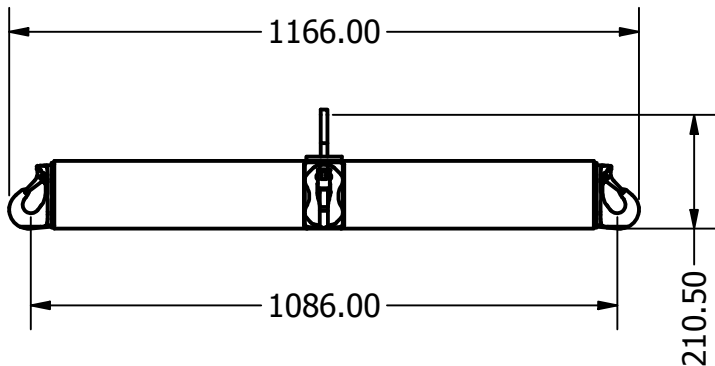
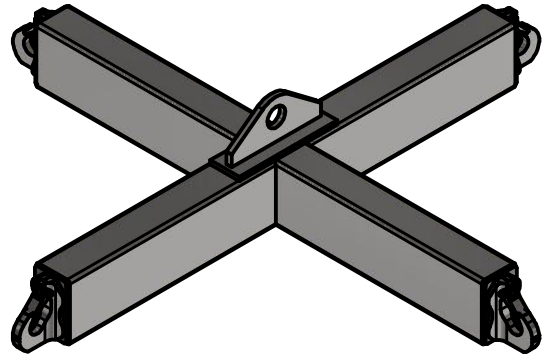

FINISH: SAFETY YELLOW

WLL: 2000 Kgs

HCoG: N/A

VCoG: N/A

TARE: 24.225 kg

STANDARDS: AS4991

NOTES:

SPECIFICATIONS SUBJECT TO CHANGE WITHOUT NOTICE

This document is the property of Bremco Metal Products P/L. It must not be copied or reproduced without the written consent of the company.

BREMCO METAL PRODUCTS

BMP069-C2T

DRAWING #:

069-C2T SP

SHEET #:

1 of 1

DATE #:

24/08/2018

REVISION :

A