

# BMP069 - FORKLIFT BAG LIFTER

www.bremco.com.au

**bremco**  
1300 273 626

## Product Description

Transport and dispense bulk bags in a safe manner using your fork lift truck. The bulk bags can be attached on the four hooks, allowing lateral movement of the bag and easy dispensing with the tied base cleanly exposed.

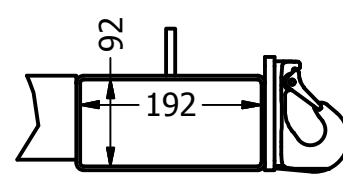
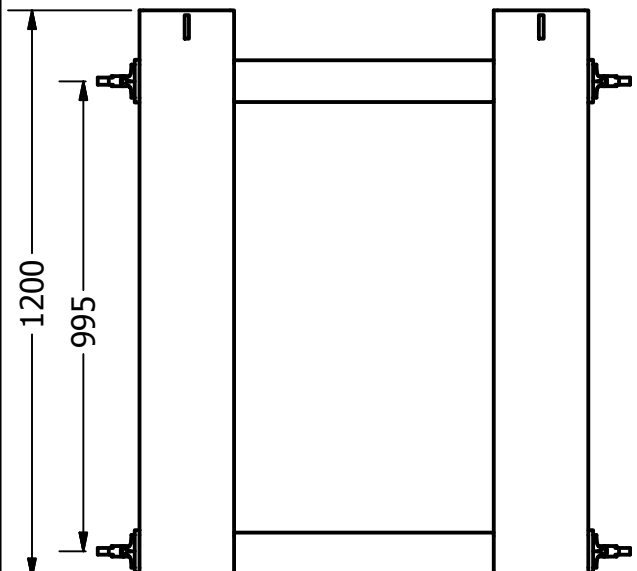
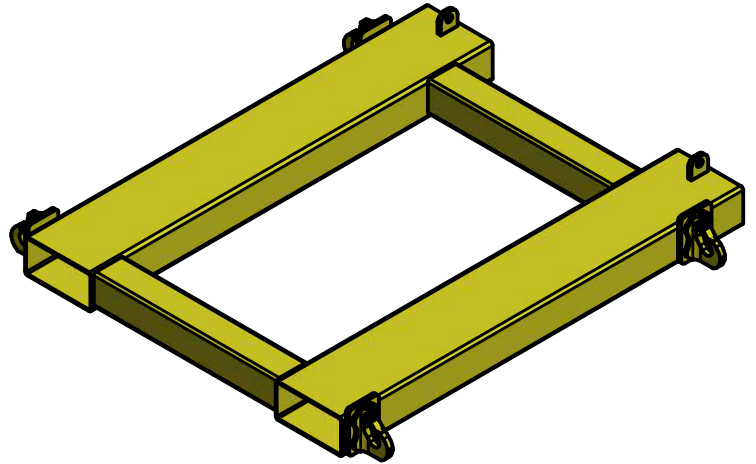

DETAIL A  
SCALE 1 / 8

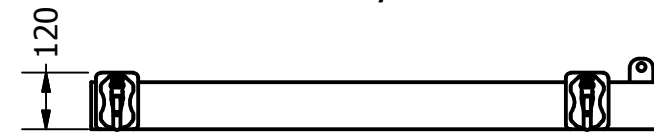
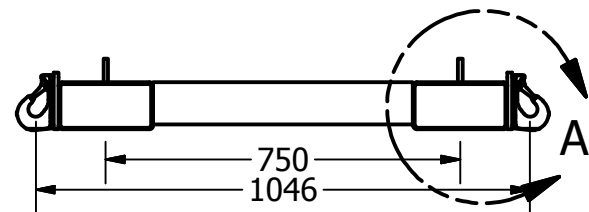

FINISH: SAFETY YELLOW ENAMEL

WLL: 2000 KG

HCoG: 610

VCoG: 51

TARE: 60.725 kg

STANDARDS: AS2359

### NOTES:

SPECIFICATIONS SUBJECT TO CHANGE WITHOUT NOTICE

This document is the property of Bremco Metal Products P/L. It must not be copied or reproduced without the written consent of the company.

BREMCO METAL PRODUCTS

BMP069

DRAWING #:  
069-SPEC

SHEET #:  
1 of 1

DATE:  
31/03/2017

REVISION:  
A