

BMP105 - Dumpmaster Crane Lift Site Bin

www.bremco.com.au



Product Description

Made in our Australian Factory

The Bremco Dumpmaster Crane Lift Site Bin is the ideal way to hoist product and then empty quickly using the rear leg lift points.

These bins can also be supplied with a 4 Leg chain assembly and have been certified in accordance with AS4991. There are several other options available upon request. These bins are supplied standard in a painted enamel finish but can also be Powder Coated or Hot Dip Galvanised POA.

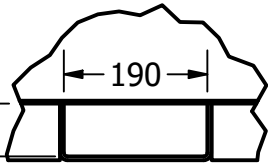
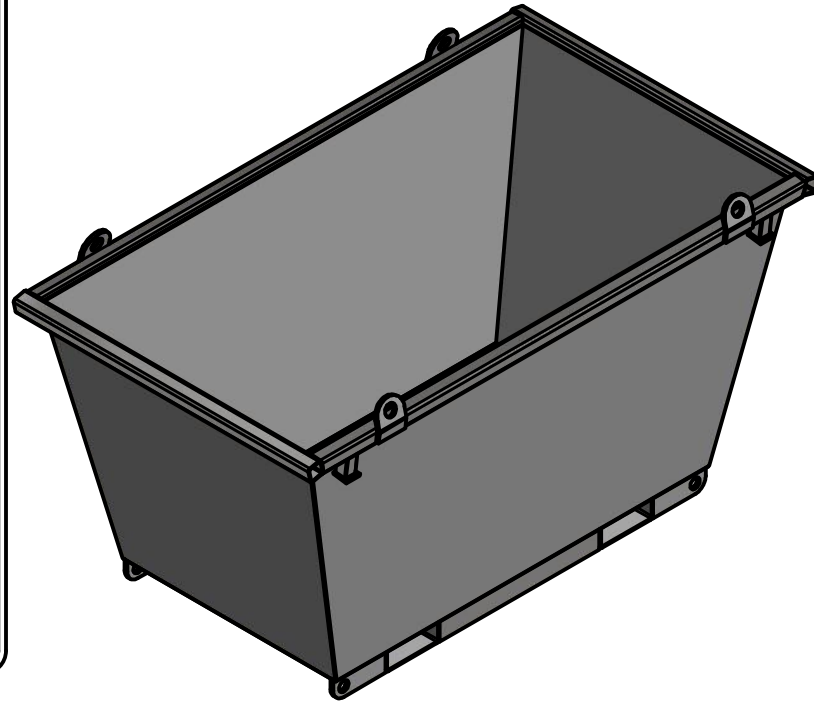

DETAIL A
SCALE 1 / 10

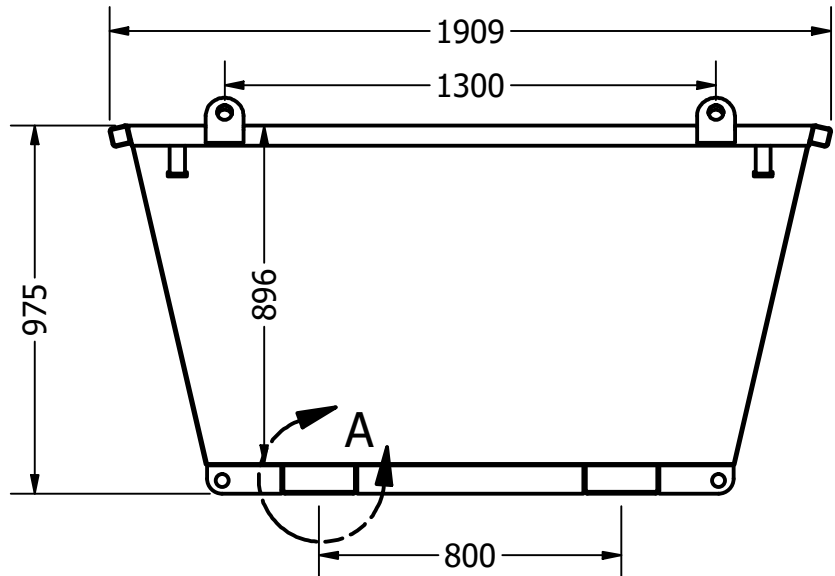
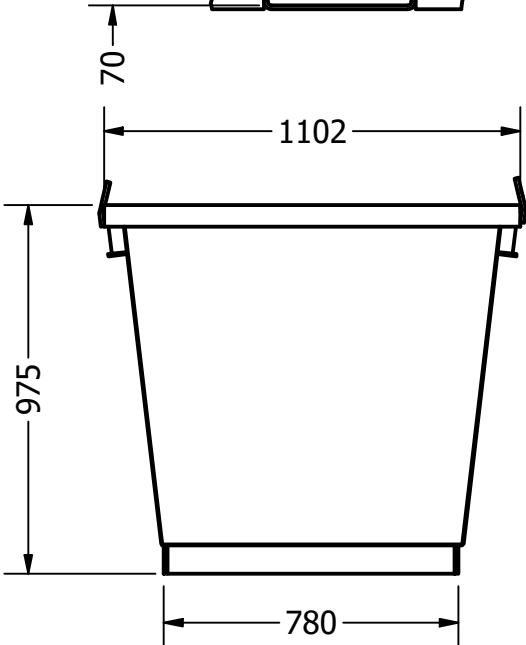

FINISH: TBA

WLL: 1500

HCoG: N/A

VCoG: N/A

TARE: 64.653 kg

STANDARDS: TBC

NOTES:

SPECIFICATIONS SUBJECT TO CHANGE WITHOUT NOTICE

This document is the property of Bremco Metal Products P/L. It must not be copied or reproduced without the written consent of the company.

BREMCO METAL PRODUCTS

BMP 105

DRAWING #:

105-SPEC

SHEET #:

1 of 1

DATE #:

9/10/2019

REVISION:

A