

# CRANE LIFT GOODS CAGE

www.bremco.com.au



## Product Description

Bremco's Goods Cage Mesh Panel Crane-Lift has been designed and engineered for use with most overhead crane systems, and can be transported using forklifts.

Bremco produces these cages with mesh panels on all side faces, a mesh floor panel, and has four lifting points fully welded into the frame that are designed in accordance with AS4991.

Note: the Goods Cage Mesh Panel Crane Lift is not to be used for lifting staff or personnel under any circumstances.

## Specifications

Overall Size = 1185mm Square x 1325mmH

Internal Size = 1105mm Square x 1040mmH

SWL = 1000Kgs

Weight of Unit 90Kgs

Powder Coat finish

Complies with AS4991

Supplied with compliance plate & serial number

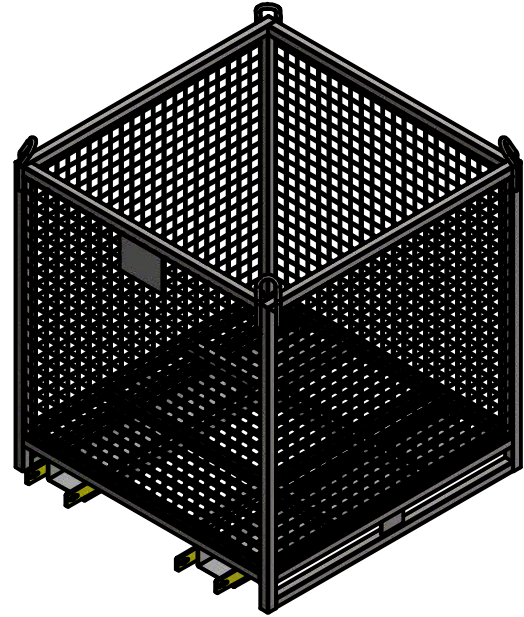

DETAIL A  
SCALE 1:8

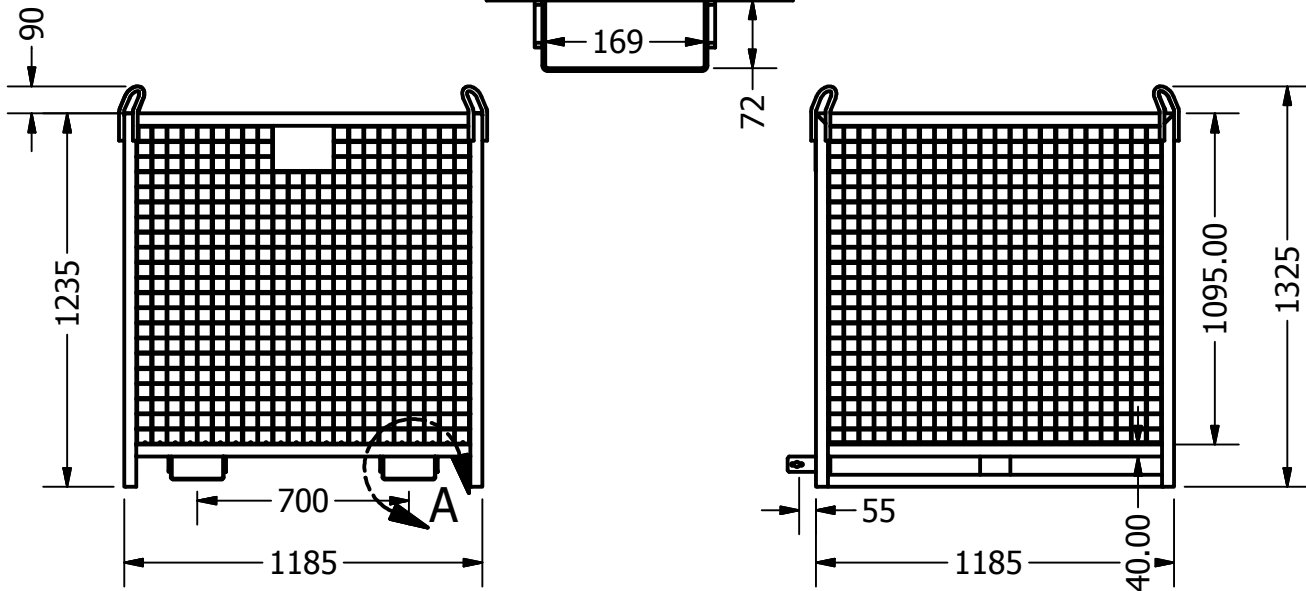

FINISH: SAFETY YELLOW

WLL: 1000KG

HCoG: 590

VCoG: 495

TARE: 110 kg

STANDARDS: AS4991

### NOTES:

**SPECIFICATIONS SUBJECT TO CHANGE WITHOUT NOTICE**

This document is the property of Bremco Metal Products P/L. It must not be copied or reproduced without the written consent of the company.

BREMCO METAL PRODUCTS

BMP124

DRAWING #:

BMP124-SPEC

DATE #:

23/02/2018

SHEET #:

1 of 1

REVISION:

A